

**AIS-CTRX TRANSPONDER
CLASS-B RX + TX**

Art.Nr.2040100

**NMEA + AIS
MULTIPLEXER**

Art.Nr.5000190

Raymarine
E / C serie

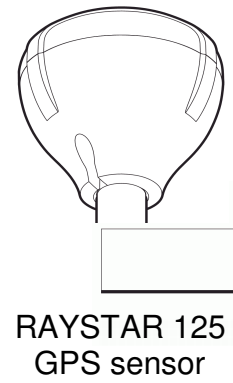
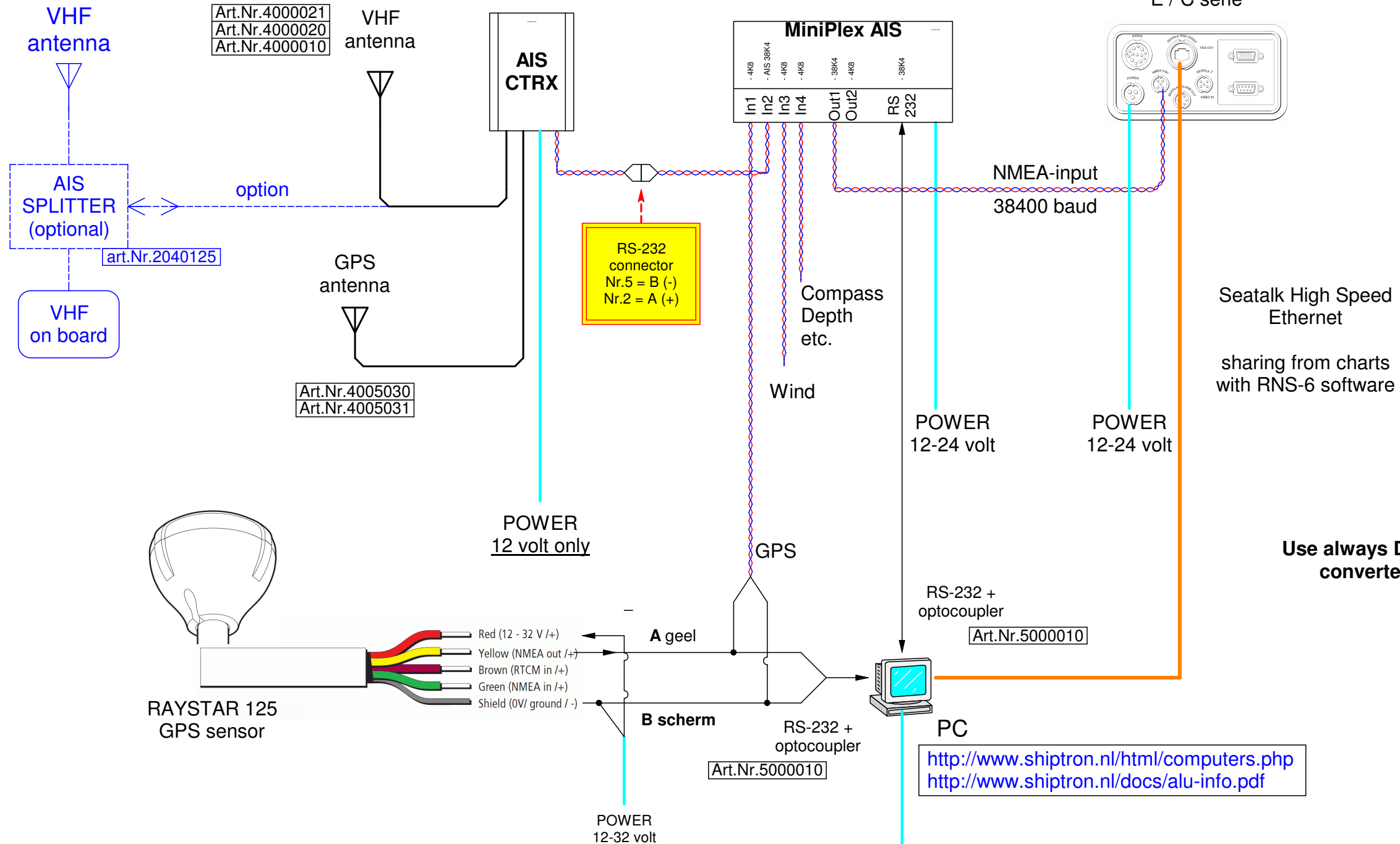

- Red (12 - 32 V /+)
- Yellow (NMEA out /+)
- Brown (RTCM in /+)
- Green (NMEA in /+)
- Shield (0V/ ground /-)

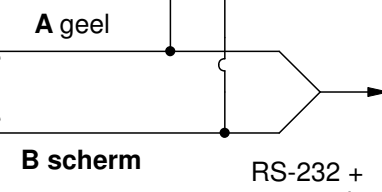

Art.Nr.5000010

PC
<http://www.shiptron.nl/html/computers.php>
<http://www.shiptron.nl/docs/alu-info.pdf>

- 9/18-12V, 4A, 50W Art.Nr.11000110
- 9/18-12V, 8A, 100W Art.Nr.11000018
- 18/36-12V, 4A, 50W Art.Nr.11000130
- 18/36-12V, 8A, 100W Art.Nr.11000140

DC-DC
convertor

POWER
12-24 volt

Note:
AIS input at miniplex-AIS
only at input 2.
No configuration needed.

NMEA cable at Raymarine plotter

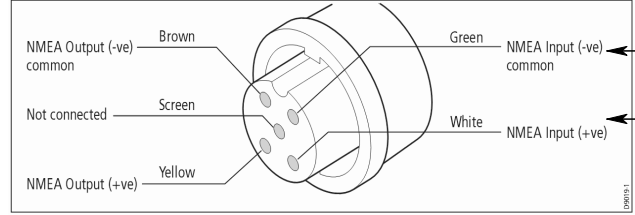

NMEA from Miniplex-AIS
at 38K4 baud

© Jugo Baya
SHIPTRON 2008

SHIPTRON
Marine Communication Specialist

De Dolfijn 24
1601 MG Enkhuizen
Holland

tel: (+31)228-317437
info@shiptron.nl
WWW.SHIPTRON.NL

title: **Raymarine + CTRX + GPS**

file: CTRX+Raymarine+GPS.flo

date: 22-2-2009 | sheet: 1 / 1 | rev: JB